

mindfull 

RESERO

Mindfull introduction

Helping the next generation
find their happy space.



Supporters



Principal

“We see everyday how students physical learning environments as significant impact on their overall wellbeing.

We need to do more to ensure their space is going to enhance their ability to learn and to be able to build positive social connections”.

Bex Skerman
Waipukurau School



Parent & Teacher

“I’ve seen how my child faces challenges fitting into learning environments, both at home and school.

To support his well-being, it is essential that he has access to spaces that cater to his unique needs”.

Anna van de Steeg
Te Mata Primary School



Neuroscience Practitioner

“By creating spaces where children can engage the lower sensory parts of their brains, we can support them to self-regulate.

Sensory environments also encourage the development of those building blocks, enhancing the resilience of the generation to come”.

Kathryn Berkett
Masters in Educational Psychology

What we're facing

Research shows up to **1/3** of the classroom suffer from mental health challenges, sensory processing conditions, or a neurodevelopmental condition.

What our classrooms look like

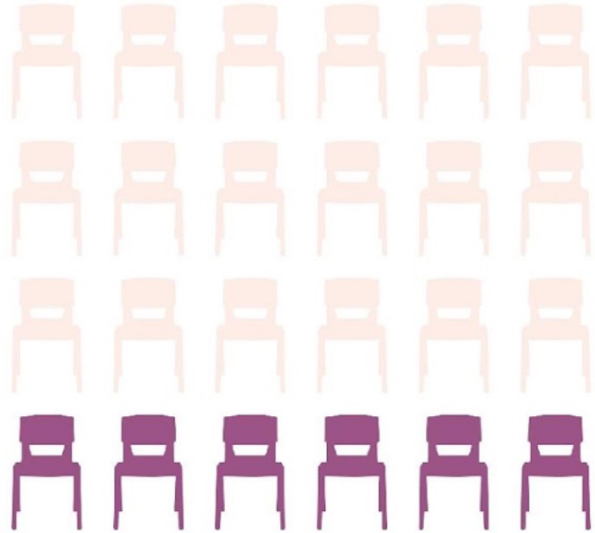

14-20%*

Mental Health Conditions

Between 14-20% of New Zealand and Australian youth are affected by depression or meet the criteria for an anxiety disorder and need support with their emotional wellbeing.

Mental health conditions among New Zealand youth have doubled in the past decade.

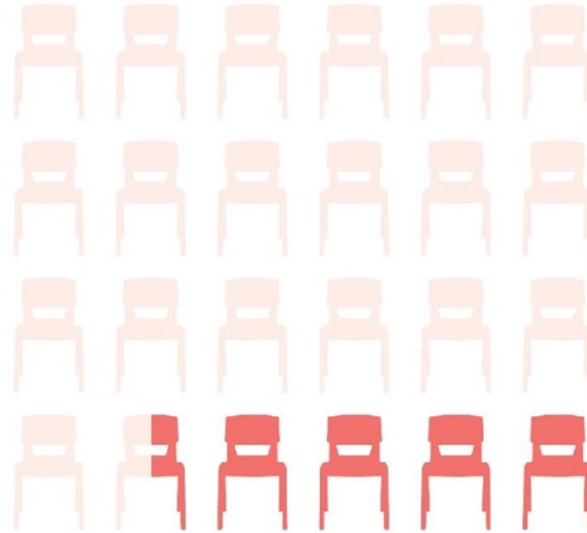

5-16%*

Sensory Processing Conditions

Estimates suggest Sensory Processing Disorder (SPD) affects 5-16% of school age children, according to SPD Australia.



3-10%*

Neurodevelopmental Condition

Estimates suggest between 3-10% of Australia & NZ children live with neurodevelopmental disorders.

This number could be under counted by up to 40% due to a lack of data/screening and children not being formally diagnosed.

Our children



I learn
Best with others



I get
Overwhelmed easily



I struggle
To sit still



I like
My own space



I learn
Best alone

Learning space evolution



Traditional

Single cell, face the front traditional classroom. Everyone is visible and has a designated space.



Open Plan

Open plan MLE ILE FLE. Large open space with 2+ classes.



Human-centred

Providing spaces for children to work how they like. Breaking up the large, noisy open-plan spaces.



Biophilic

Inspired by nature, bringing health & wellbeing benefits.

Initial product range users



3 - 5 years



5 - 10 years

Future R&D and product



12 - 17 years

Biophilic colour theory - Design inspiration

Biophilic colour theory show how certain colours and tones drawn from nature impacts us in subtle yet effective ways.



Productivity, Happiness, Enthusiasm, Motivation, Serenity, Soothing, Efficiency, Reflection



Happiness, Comfort, Creativity, Inspiration, Enthusiasm, Equilibrium, Productivity, Motivation



Creativity, Inspiration, Productivity, Confidence, Spirited



Clarity, Inspiration, Happiness, Creativity, Motivation, Enthusiasm, Productivity



Happiness, Security, Substance

Biophilic influences

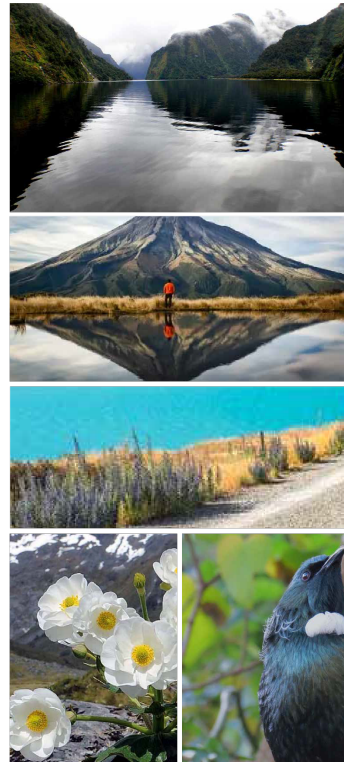

Extracted Palette



Biophilic colour theory

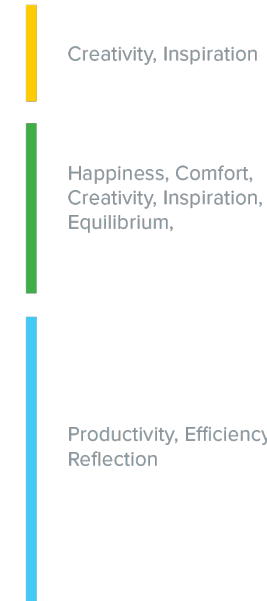

Biophilic colour theory - Design inspiration

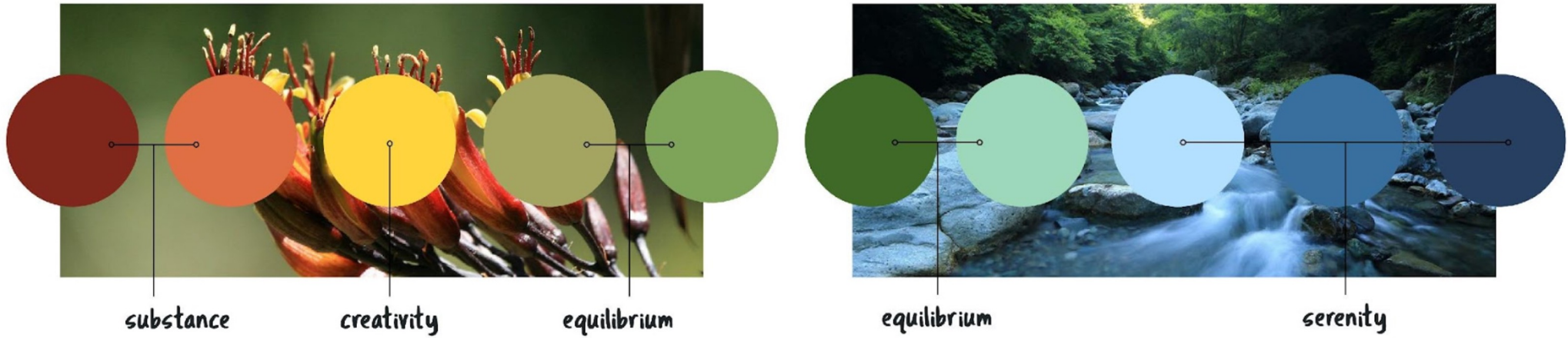

energy

focus/balance

calm

Product range



Hideaway
Hood



Laylow
Pad

Wobble
Seat



Rocking
Perch



Laylow
Raft

Learning
Hut



Biophilic Design

energy

focus/balance

calm



Find your happy space

How will product be used

Mindfull products have been designed to fit into **every learning space** – not just sensory spaces



Mission

Designed to ease the burden on teachers by allowing learners to **self-select** their desired level of stimulation

Hideaway Hood



Hideaway Hood

The Hideaway Hood provides a personal refuge for kids in search of sanctuary. Creating the space to carry out a solo task, take a break or just reset

Find your happy space

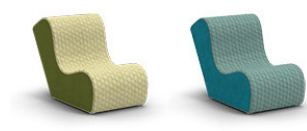
Product Name	Hideaway Hood
Features	<ul style="list-style-type: none">• Creates solo refuge in an open plan learning environment• Acoustic hood reduces distractions and increases focus• Allows students to self regulate, enhancing personal wellbeing• Materials, colours and textures directly inspired by nature• Durable timber construction with commercial grade upholstery
Size	Hood: 535 W x 1100 D x 1200 H Seat: 440 W x 800 D x 540
Materials	FSC Plywood, Polyester & Wool Blend Fabric, PET Acoustic Panel, Steel
Assembly	Assembly required
Warranty	2 years
Colours	 Green Blue
Options	 Green Blue Hideaway Seat Hideaway Seat

Dimensions

Design Registered in
New Zealand & Australia

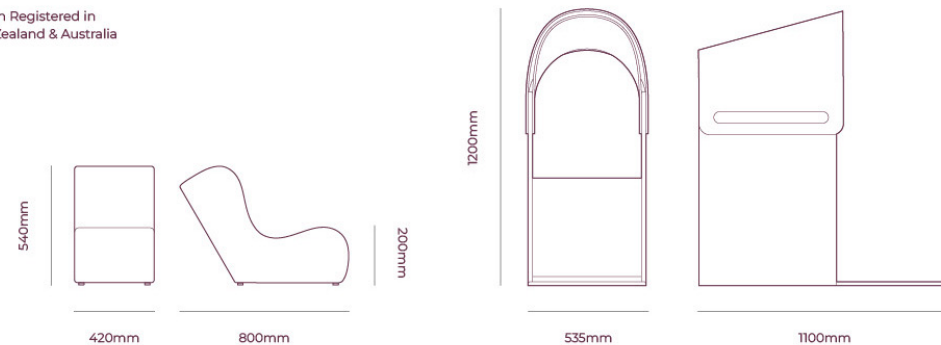

Rocking Perch



Rocking Perch

The Rocking Perch inspires rhythmic movement while the ribbed seatpad creates a sensory experience. Giving students the ability to self-regulate and be in control of their wellbeing.

Find your happy space

Product Name	Rocking Perch
Features	<ul style="list-style-type: none">• Increases student comfort allowing them to stay focused for longer• Rocking allows students to stay active within a stationary area• Upholstered ribbed seatpad provides a sensory experience• Materials, colours and textures directly inspired by nature• Durable timber construction with commercial grade upholstery
Size	305 W x 475 D x 225 H
Materials	FSC Plywood, Polyester Blend Fabric, Wool Blend Fabric
Assembly	Ships assembled
Warranty	2 years
Colours	 Green Blue Orange Red

Dimensions

Design Registered in
New Zealand & Australia

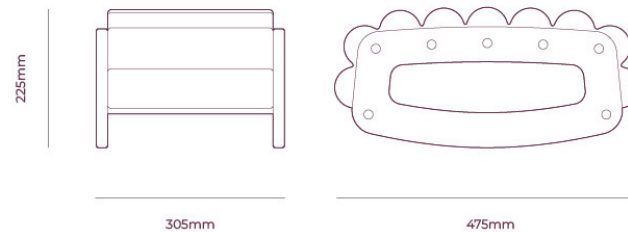

Laylow Pad



Laylow
Pad

The Lay Low Pad creates a comfortable and personal area for sitting or lying. The pads can easily be flipped to provide contrasting textures allowing students to decide their sensory experience.

Find your happy space

Product Name	Laylow Pad
Features	<ul style="list-style-type: none">• Creates a personal area within a shared environment• Dual textured upholstery allows alternate sensory experiences• Increases student comfort allowing them to stay focused for longer• Materials, colours and textures directly inspired by nature• Commercial grade upholstery
Size	400 W x 400 D x 150 H
Materials	Wool Blend Fabric, Polyester Blend Fabric
Assembly	Ships assembled
Warranty	2 years
Colours	 Green Blue Orange Red

Dimensions

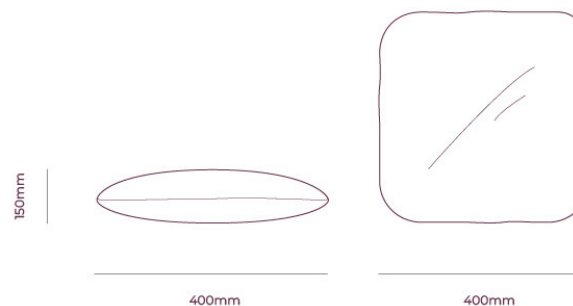

Laylow Raft



Laylow
Raft

The Lay Low Raft can be folded, coiled or curled to create personal or shared spaces. Upholstered in contrasting textures allows students to decide their sensory experience.

Find your happy space

Product Name	Laylow Raft
Features	<ul style="list-style-type: none">• Creates a flexible and adaptable low-to-ground breakout area• Dual textured upholstery allows alternate sensory experiences• Increases student comfort allowing them to stay focused for longer• Materials, colours and textures directly inspired by nature• Commercial grade upholstery
Size	1000 W x 450 D x 70 H
Materials	Wool Blend Fabric, Polyester Blend Fabric
Assembly	Ships assembled
Warranty	2 years
Colours	 Green Blue Orange Red

Dimensions

Design Registered in
New Zealand & Australia

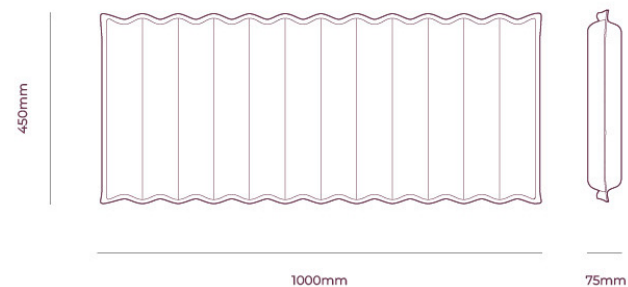

Wobble Seat

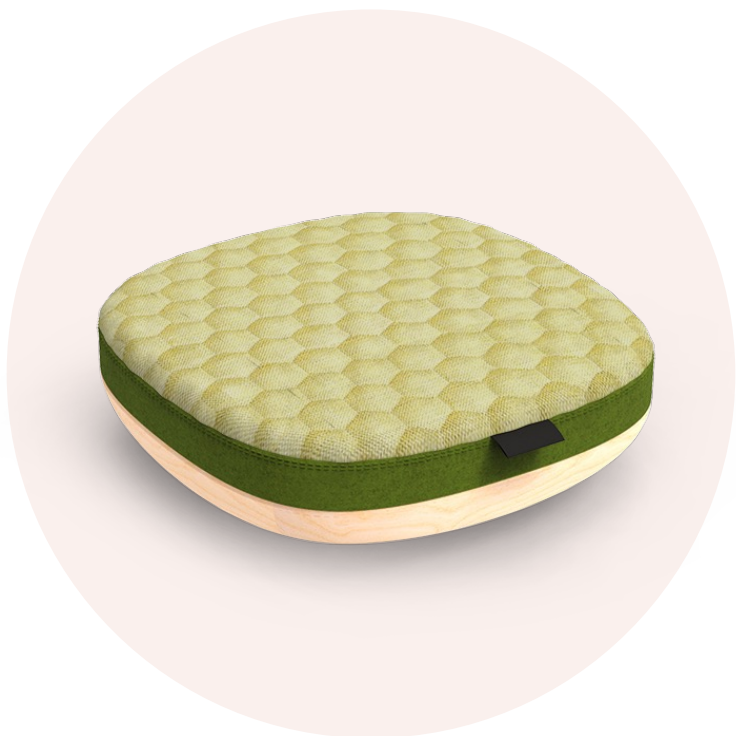

Wobble Seat

The Wobble Seat provides dynamic movement allowing students to rotate, tilt and stay active in a stationary environment. Comfort and focus in one.

Find your happy space

Product Name

Wobble Seat

Features

- Increases student comfort allowing them to stay focused for longer
- Rotation and tilt allows students to stay active within a stationary area
- Upholstered seat provides a tactile sensory experience
- Materials, colours and textures directly inspired by nature
- Durable timber construction with commercial grade upholstery

Size

380 W x 380 D x 135 H

Materials

Hardwood, Polyester Blend Fabric, Wool Blend Fabric

Assembly

Ships assembled

Warranty

2 years

Colours

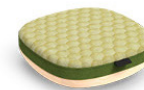

Green



Blue



Orange



Red

Dimensions

Design Registered in New Zealand, Australia, China, Hongkong and Singapore

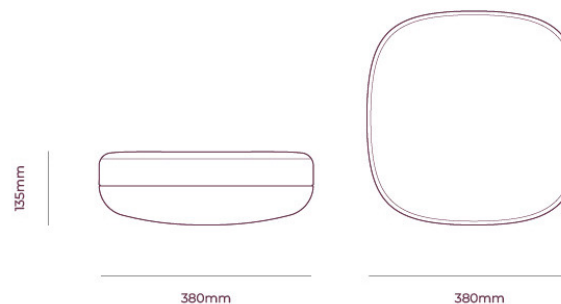



Learning Hut



Learning Hut

The Learning Hut provides a refuge space for up to 4 students to gather and collaborate together, free from distraction. Separation without isolation.

Find your happy space

Product Name	Learning Hut
Features	<ul style="list-style-type: none">• Creates a landmark within the classroom for students to gather• Integrated seating and table allows for up to 4 students to collaborate• Divides space and creates more ownable areas within the classroom• Materials, colours and textures directly inspired by nature• Durable timber construction with commercial grade upholstery
Size	Hut: 1235 W x 700 D x 1700 H Seat: 360 H Table: 550 H
Materials	FSC Plywood, Polyester Blend Fabric, PET Acoustic Panel, Steel
Assembly	Assembly required
Warranty	2 years
Colours	 Green Blue Orange
Options	 Green/Blue/Orange Seatpad Topper

Dimensions

Design Registered in New Zealand, Australia, China, Hongkong and Singapore

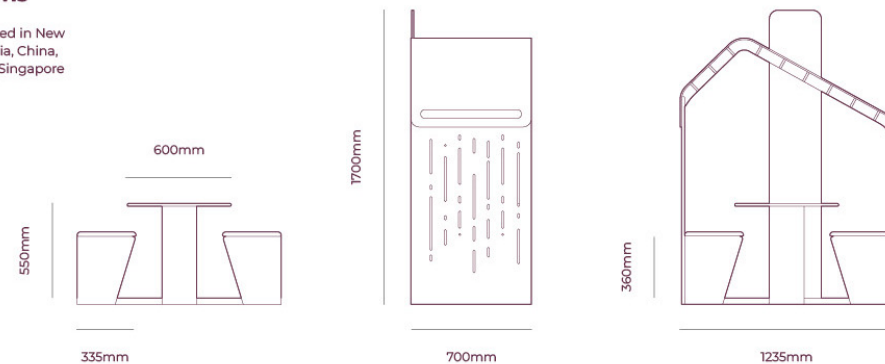

Product range



Hideaway **Hood**

\$1,399 NZD
\$1,299 AUD

Can be paired with
Hideaway seat for
\$698NZD



Laylow **Pad**

\$179 NZD
\$169 AUD

Wobble **Seat**

\$329 NZD
\$299 AUD



Rocking **Perch**

\$349 NZD
\$329 AUD



Laylow **Raft**

\$269 NZD
\$249 AUD

Learning **Hut**

\$2,499 NZD
\$2,299 AUD



Excluding seat pads

Classroom packages



Mindfull Room

\$5,499 NZD
\$4,999 AUD

Excludes seat pads &
Hideaway seat



Mindfull Floor

\$1,999 NZD
\$1,899 AUD

Find your happy space

mindfull 

mindfull 

*Everyone deserves
a happy space*